

REVISION		
REV	DATE	DESCRIPTION
1	20-SEP-2019	FIRST EDITION
2	04-DEC-2019	UPDATE TABLE DATA

- NOTES:
- Min. Clearance on all sides must be 36 inch / 90 cms, for proper ventilation and maintenance.
 - Recommended tight torques for wires terminals:
208 to 460 Volt wire: 35 Lbs/in²
115 Volt wires: 20 Lbs/in².
 - Normal operation ambient temperature MAX 105°F/40°C.
 - Flex connctors will be shipped loose.
 - Information subject to change without notice.

- NOTAS:
- Espacio mínimo alrededor del equipo 36 inch / 90 cms para garantizar adecuada ventilación y mantenimiento.
 - Torque recomendado de apriete para terminales de cables:
Cables de 208 V a 460 V: 35 Lbs/in²
Cables 115 V: 20 Lbs/in²
 - Temperatura ambiente de operación MAX: 105 °F / 40 °C.
 - Las mangueras flexibles se envían sueltas.
 - Información sujeta a cambios sin previo aviso.

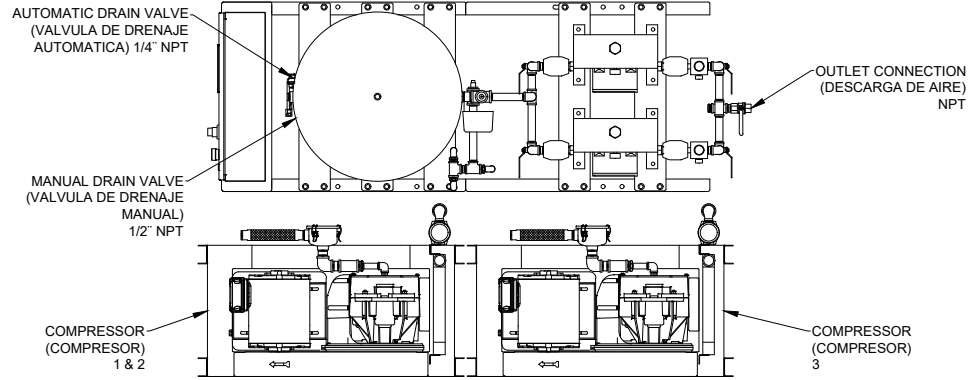

TANK CAP.	H	WEIGHT
Gal	in	Lbs
Lts	mm	Kgr
120	T.V	T.V
454	T.V	T.V
200	89	T.V + 180
757	2261	T.V + 82
240	100	T.V + 240
908	2540	T.V + 109

T.V: TABLE VALUE / VALOR DE TABLA

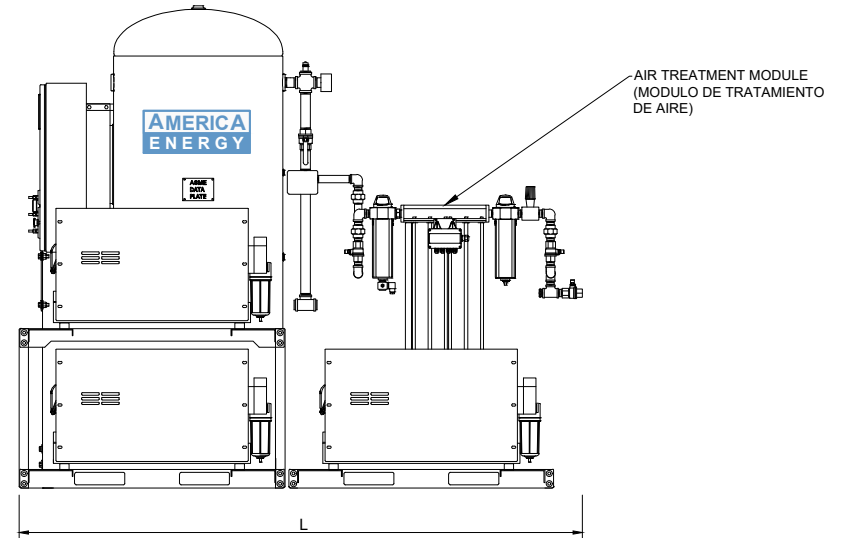
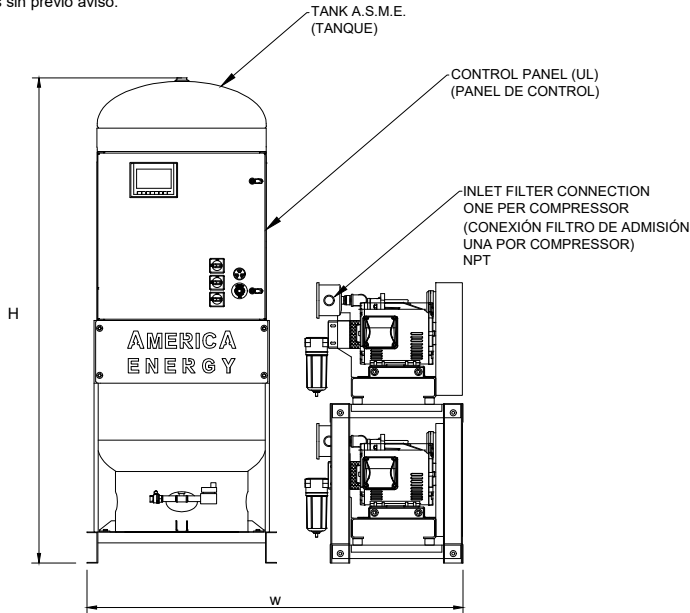

MODEL	HP	CONN.		TANK SIZE	CONF	PUMP FLOW		SYSTEM NFPA FLOW				PUMP AMP						BTU/hr	SOUND LEVEL	DIMENSION			WEIGHT
		IN	OUT			FLOW		ONE PUMP STANBY				TOTAL SYSTEM AMP								L	W	H	
						each module		cfm				TOTAL SYSTEM AMP											
						cfm		m3/hr				TOTAL SYSTEM AMP											
				Gal		cfm		@ 50 psig	@ 100 psig	50 Hz	60 Hz						Db (A)	in	in	in	Lbs		
				Lts		m3/hr				190V	380V	208V	230V	400V	460V		mm	mm	mm	Kgr			
		NPT	NPT																				
		in	in																				

AMERICA ENERGY, INC
Right Solution for Compressed Air & Vacuum Systems
www.america-energy.com

TITLE: DIMENSIONAL DRAWING MEDICAL AIR SYSTEM
SCROLL 3HP_10HP TRIPLEX

DRAWING: J.E. DATE: 04-DEC-2019 DWG No DD-AES-O30_100MT-120_240-S-NNXRev2
DESIGN: A.A. SCALE: S/E
CHECKED: A.A. SHEET: 1/1

THIS INFORMATION IS PROPERTY OF AMERICA ENERGY, INC. AND MAY NOT BE GIVEN TO ANY OTHER PARTY WITHOUT THE CONSENT OF AMERICA ENERGY, INC.

X = CONTROL PANEL TYPE (E: ELECTRONIC / T: TOUCH SCREEN / TW: TOUCH SCREEN & WEB COMMUNICATION)